

LOAD RATINGS		
RATING	lbf	Newtons
RADIAL BASIC DYNAMIC	6,385	28,402
MAXIMUM STATIC CAPACITY	7,920	35,230

- NOTES:
1. BEARING IS PACKED WITH NLGI GRADE 2, LITHIUM BASED GREASE (UNLESS OTHERWISE SPECIFIED)
 2. ALL EXPOSED STEEL SURFACES HAVE BLACK OXIDE
 3. CUSTOM LASER ETCHING AVAILABLE UPON REQUEST
 4. LIMITING SPEED:
A. GREASE = 2,200 RPM

RECOMMENDED MOUNTING HOLE Ø		
Limit	Inch	mm
MIN	1.002	25.451
MAX	1.004	25.502

MAXIMUM CLAMPING TORQUE**		
Thread Type	Inch lbf	Nm
LUBRICATED	625	70.6

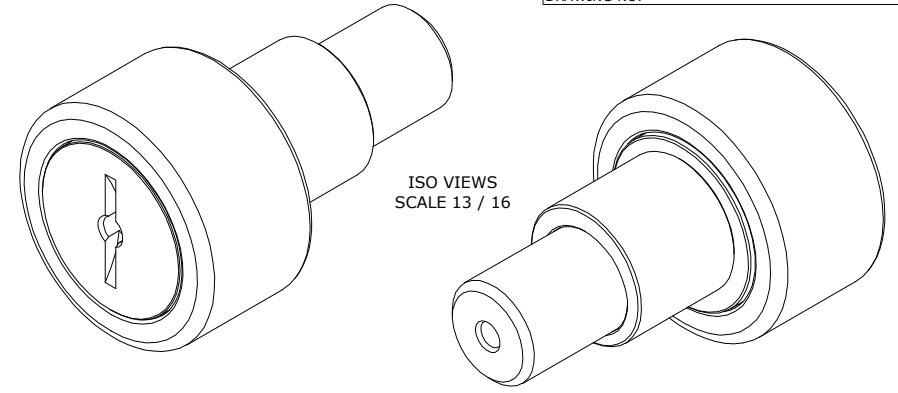

ISO VIEWS
SCALE 13 / 16

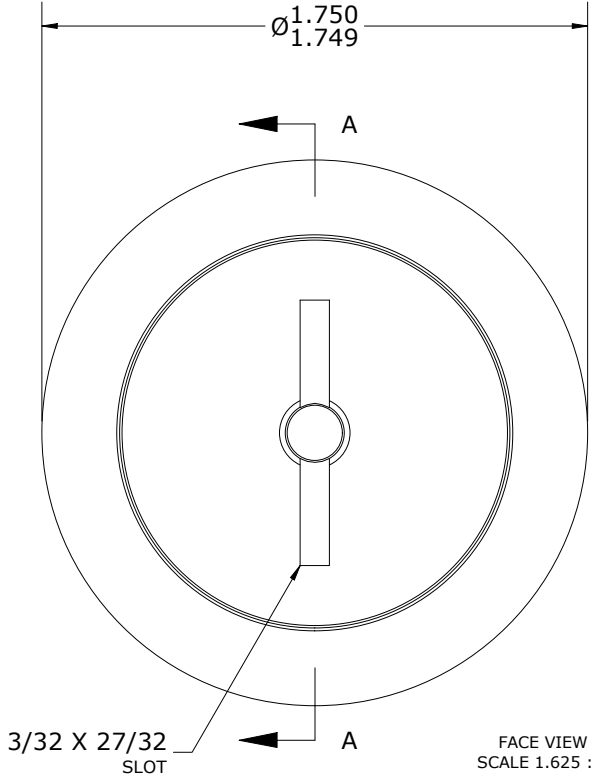

FACE VIEW
SCALE 1.625 : 1

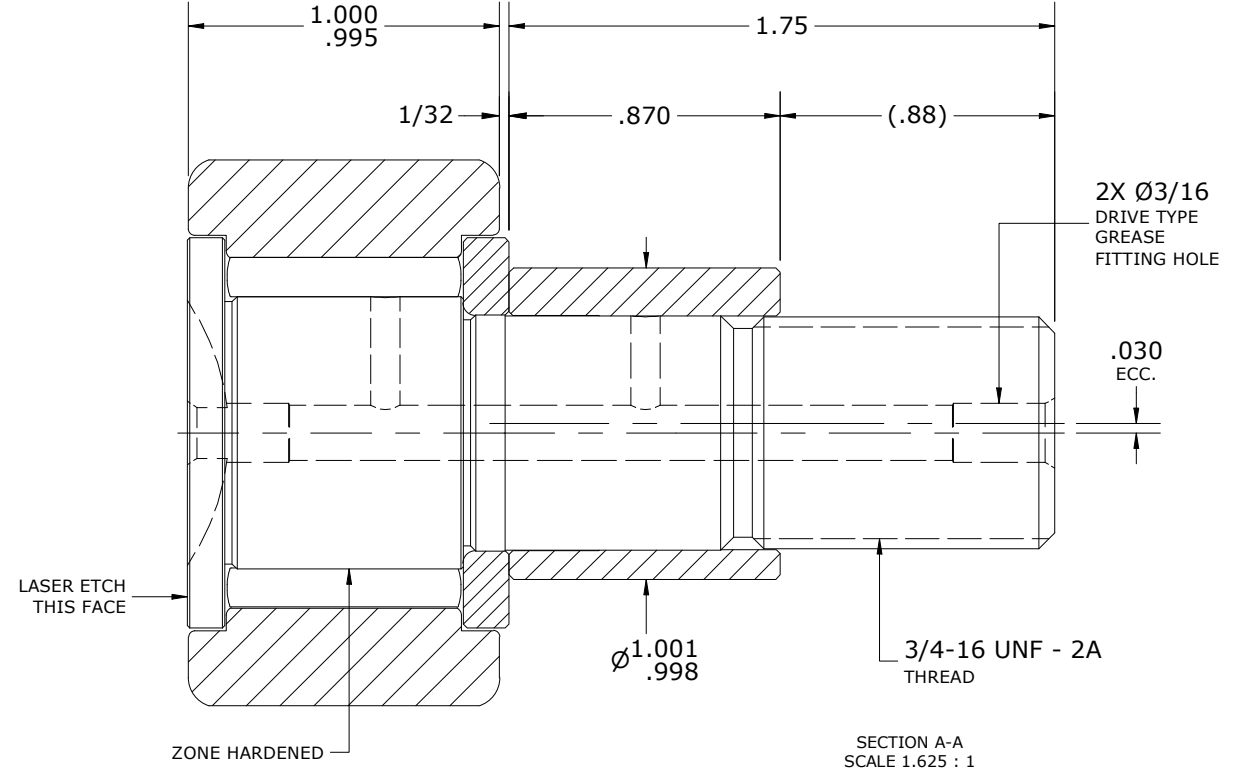

SECTION A-A
SCALE 1.625 : 1

TORQUE SPECIFICATION IS BASED ON LUBRICATED THREADS, IF USING DRY THREADS DOUBLE TORQUE VALUE

MATERIAL NOTES:
 OUTER RING - BEARING STEEL, HEAT TREATED
 STUD - BEARING STEEL, ZONE HARDENED
 NEEDLE ROLLER(S) - BEARING STEEL, HEAT TREATED
 WASHER - BEARING STEEL, HEAT TREATED
 ECCENTRIC SLEEVE - STEEL

CUSTOMER PART#	XX = ± .01 XXX = ± .005 XXXX = ± .0005 ANGLES = ± 2' INCH [METRIC] FRACTION = ± 1/64
ENGINEERING CHANGE ORDER NOTE	
CARTER STANDARD SURFACE FINISH IS MEASURED IN "Ra" UNITS UNLESS OTHERWISE SPECIFIED.	

CARTER MANUFACTURING IS NOT RESPONSIBLE FOR TYPOGRAPHICAL ERRORS				CARTER MANUFACTURING CO., INC. GRAND HAVEN, MICHIGAN 49417	
REVISION		PART NAME: ASSEMBLY		PRODUCT TYPE: Standard CF	
B	AUTHOR BY HG	DRAWN BY JAF	CHK'D BY MD	SALES NC	MATERIAL NOTED
REVISION BY DJB	DATE 3/24/2026	DATE 7/13/2006	DATE 3/24/2026	DATE 3/24/2026	SHEET 1 OF 2